

MasterMover



handling solutions for
Healthcare

About Us

MasterMover is the award-winning manufacturer of pedestrian electric tugs and widely recognised as a market leader in providing solutions for moving wheeled loads.

Since the company's inception in 1995 MasterMover have provided handling solutions to some of the biggest brand names in industry, both nationally and globally. Today MasterMover has a portfolio stretching to 23 models, all designed to safely and efficiently transport wheeled loads. Deployed across the World, MasterMover products are used within a range of industries in the UK, mainland Europe, Asia, Australia and also North and South America. The Derbyshire based company are committed to design and manufacturing and employ skilled people, many of whom live locally.

Process of Sale

The MasterMover sales process is entirely focussed on delivering the very best in customer service.

- Following your initial enquiry a member of our sales team will discuss your requirements in detail by phone and propose a solution in principle.
- One of our skilled engineers will then visit your site and carry out a machine demonstration. At the same time our engineer will also complete a thorough technical assessment of your requirements.
- Once we have visited site we then provide a definitive specification and costs. In addition to outright purchase, our sales team would be delighted to discuss options for contract hire or contract purchase.
- On delivery, your machine will be set up and commissioned by one of our skilled engineering team. He will make sure that it operates exactly as it should in your environment and he will then go through the MasterMover training programme with your staff.

Our guarantee to you

MasterMover wants to offer the very best to our customers. It is our responsibility to ensure the handling solution delivered is fully mobilised and effective in accordance with your requirements. If you are not satisfied with the solution we have installed then we will provide an alternative product replacement or refund*. This guarantee offers you complete peace of mind.



*The guarantee is part of our terms and conditions of sale. Details are available upon request.



Contents

Healthcare	2
SmartMover	3-4
BedMover	5-6
MasterTug	7-8
Gas Bottle Mover	9-10
Ride-on Tug	11-12
Support	13-14

Complete handling solutions for healthcare

The 'Hospital Range' from MasterMover is focussed on simple to use and practical solutions that make moving everything from patients to paper a safe and easy task.

Since 1995, MasterMover has worked closely with the NHS. With hundreds of machines being used in hospitals all over the UK our relationship with the NHS has gone from strength to strength. This unrivalled success in hospital environments is born from the fact that all of our machines are highly compact and very manoeuvrable which makes them perfect for the busy hospital of today.

Our business offering to the NHS doesn't stop at providing the best in materials handling solutions. We also have a highly skilled team of engineers who, as well as maintaining MasterMover machines, can provide a complete maintenance solution for any of your materials handling equipment.

Whatever you want to move, MasterMover are uniquely placed to offer a tailored solution for your hospital.



SmartMover



The SmartMover, a compact towing device with a unique combination of power, control and manoeuvrability

The SmartMover is a versatile machine designed for moving roll cages and trolleys across uneven surfaces. The unit ensures that the roll cage cannot be tipped onto the operator by clamping to the base of the cage. Efficiency and safety are also improved by moving multiple cages using the towing links. Sealed batteries, variable speed and auto braking are also standard.

Whilst the SmartMover is designed primarily for moving roll cages, its compact size makes it ideal for moving a range of loads from sterilisation trolleys through to waste bins. Used by a huge number of trusts across the UK, the SmartMover offers the perfect alternative to manually pushing heavy loads through congested hospital corridors.

- Enables safer and more efficient ward deliveries
- Compact size makes it ideal for hospital corridors
- Highly manoeuvrable for use in tight spaces

Dimensions



Benefits

- Moves loads up to 1,000Kg
- Operates on slopes and inclines
- Reduces injuries and operator fatigue
- Quiet in operation
- Non marking tyres
- Brake & throttle control

Key Features

- Clamp with safety lock

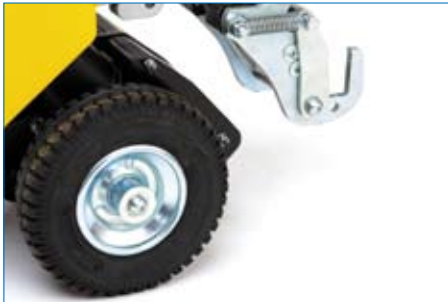

- Variable speed with emergency stop



Options

- Multiple height adjustment
- Link bars for multiple cages



BedMover



Powerful, easy to use and highly manoeuvrable, the BedMover is the perfect patient moving solution.

The new BedMover from MasterMover is a compact machine designed specifically for moving patient beds and trolleys in a hospital environment. It uses a unique coupling mechanism which enables quick and simple connection to any bed! The ergonomic controls make it very easy to use and, with the BedMover, moving patients becomes a safe one person task. The BedMover is also designed with infection control in mind. It features an anti-microbial coating but is engineered to comfortably withstand a thorough clean with soap and hot water!

- Attaches to all beds
- Moves bariatric patients
- Only needs one operator
- Quiet operation ensures minimal disturbance
- Easy clean for infection control
- Operates from either end of the bed

Dimensions

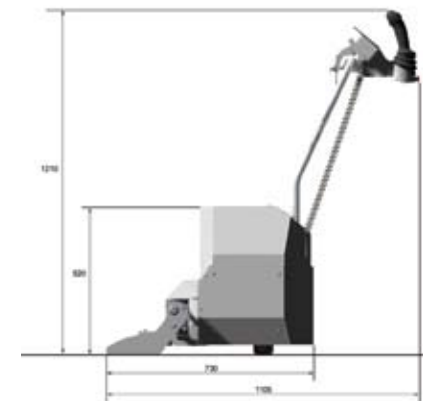
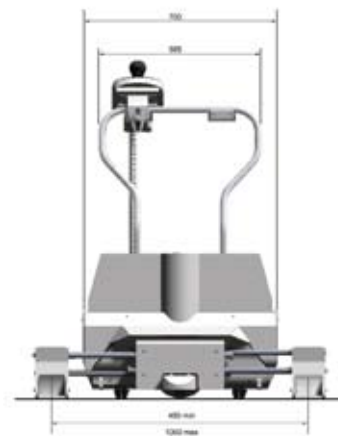

Benefits

- Increased productivity
- Reduces manual handling
- Improves safety
- Easy to use



Key Features

- Ergonomic joystick control



- Anti-microbial white paint



MasterTug



The MasterTug, pulls, pushes and steers wheeled loads from 50Kg to 2400Kg

The MasterTug RCM is a powerful yet compact pedestrian operated tug unit, capable of towing loads up to 2400Kg. The tug is used throughout the NHS for moving everything from roll cages through to medical records trolleys. Like all of our machines it is designed with safety in mind with programmable throttle control, electromagnetic safety brake and anti crush button fitted as standard. Its ease of use and compact size make it ideal for use in congested hospital corridors.

- Used to move roll cages in batches of up to five
- Throttle control & electromagnetic safety brake ensure absolute safety
- Durable in any weather
- Strap system available for towing up to sixteen empty nested roll cages

Dimensions

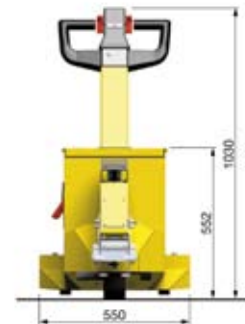

Benefits

- Increased productivity
- Reduces manual handling
- Improves safety
- Easy to use
- Moves loads up to 2400Kg

Options

- Strobe light & bleeper
- On-board charger
- Interchangeable battery pack for 24hr use
- Keyless start



Key Features

- Accurate battery life indicator



- Couplings with height adjustment



Gas Bottle Mover



The Gas Bottle Mover - the safest and easiest way to move delicate bottles of pressurised gas.

The oxygen bottle mover is designed to address the problems with moving oxygen bottles from an outside store and into the hospital. The machine is capable of moving a large number of bottles of all sizes in a single movement enabling the porters to make more efficient ward deliveries with a dramatic reduction in manual handling.

- Suitable for moving full & empty oxygen bottles & attachments
- Transports bottles of every size
- Durable in any weather
- Enables more efficient ward deliveries
- Throttle control & electromagnetic safety brake ensure absolute safety

Dimensions

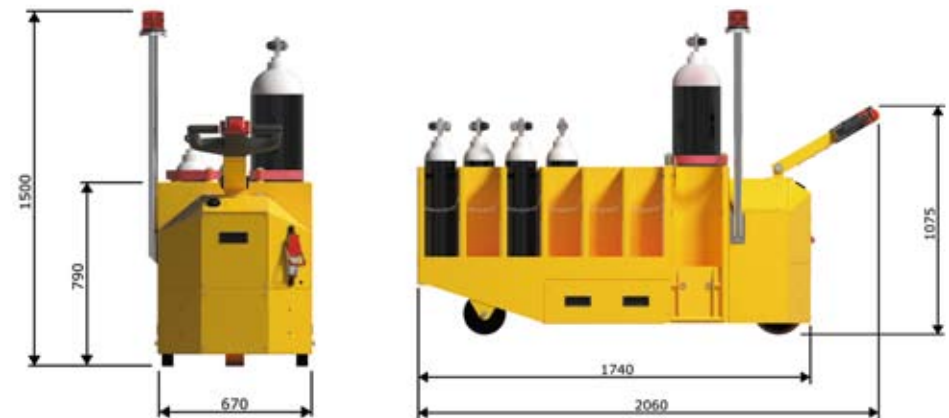

Benefits

- Less manual handling
- Increased productivity
- Safe movement of larger bottles
- Compatible with lifts
- Move multiple bottles on one trip

Key Features

- Gas bottle safety chains



- Access ramp



Options

- Choice of 16 or 20 bottle capacity
- Strobe light & bleeper
- Choice of colour



Ride-on Tug



The Ride-on Tug - perfect for moving trolleys of 2000Kg around the hospital

The MasterMover Ride-on Tug allows the swift and safe movement of loads across large hospital campuses. Designed for outside use, the ride-on tug is perfect when the distance to be travelled is just too great. With a simple tow pin attachment, the ride-on can be used to tow a wide range of loads from waste bins through to general trailers.

Benefits

- Small turning circle makes the ride-on ideal for tight spaces
- High capacity batteries allow the unit to cover large distances
- Capable of towing loads up to 2,000kg
- Non-marking tyres allow use inside without the risk of damaging floors

Dimensions

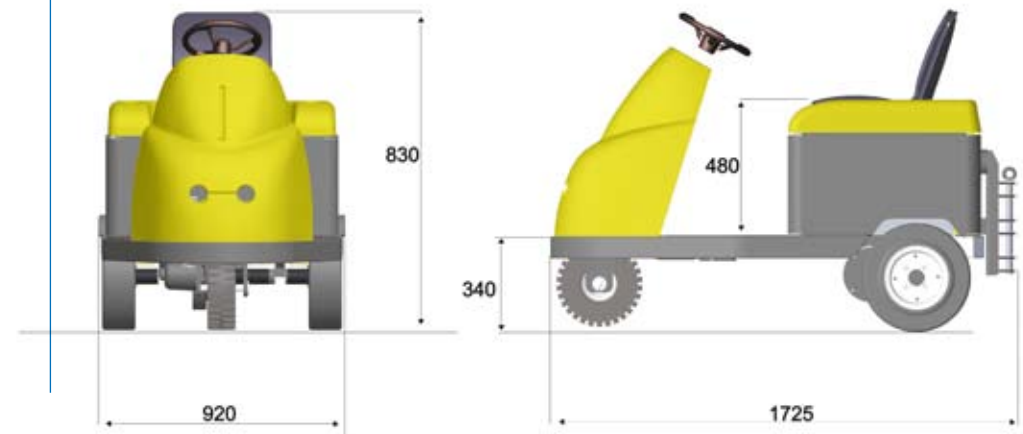

Options

- 3 power choices
- Cab for weather protection
- Road lights with indicators
- Warning beacon with motion bleeper

Key Features

- Non marking tyres



- Small turning circle

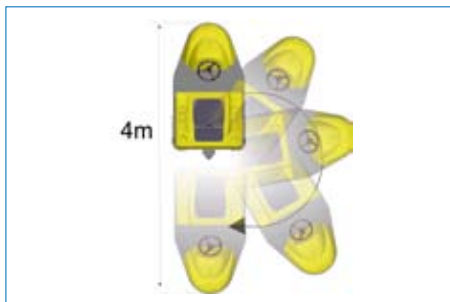

Support

All MasterMover machines will need to be serviced regularly during their lifetime. MasterMover understand the importance of providing a prompt and efficient service to its customers at all times.

Maximum uptime

Our service engineer's knowledge of your equipment, supported by a diagnostic analysis, will quickly identify any problem and return your machine to normal service with the minimum delay.

Efficient service

Overnight delivery of parts and spares are made directly to our regional depots, ensuring a rapid response and first-time fix for all your machine requirements. This, coupled with GPS and a messaging system within our fleet, enables engineers to receive breakdown calls as soon as they are reported. The real time data allows an extremely accurate ETA to be given to our customers.



Maintenance & warranty contract review

We will conduct an annual appraisal of your machine use, service performance and choice of service contract, as well as discussing any health & safety or productivity issues you may have.



Operator training

We offer a comprehensive range of instructor and operator training courses, ensuring the maximum benefits from your machine are recognised.

Flexible service plans

Our service department offers a wide range of flexible service plans tailored to suit your individual requirements, and the additional warranty cover ensures you will always have complete peace of mind. Details of our gold, silver and bronze service packages, full parts warranty and major component warranty are available upon request.

Service plans

Bronze:

- 2 full services per year
- Safety maintenance plan

Silver:

- 2 full services per year
- Safety maintenance plan
- 2 preventative inspections
- Parts schedule option

Gold:

- 4 full services per year
- Safety maintenance plan
- Parts schedule option
- Major component warranty
- Training
- Payment Plan

Expert advice given at all times along with detailed service reports to show your paper trail of history & maintenance.



Our service to you

The MasterMover technical service team are extensively trained and dedicated to providing a quick and hassle-free service to our customers. With a tracking and messaging system fitted to a national fleet of vehicles, the engineers can deliver a fast and professional service every time. Our engineers carry vehicle stock supported by parts dispatched from our service department. These are delivered overnight and ensure a rapid response. In addition to this, we offer peace of mind service contracts and operator training as well as arranging individual service requirements. We are also accredited with the Contractors Health and Safety Assessment Scheme (CHAS) and Safe Contractor making access to your site safe and efficient. Our objective is to offer lifetime product support to your investment and maintain a service level that exceeds your expectations.



handling solutions for
Healthcare



MasterMover

Airfield Industrial Estate
Moor Farm Road
Ashbourne, Derbyshire,
DE6 1HD
United Kingdom

Telephone: +44 (0) 1335 347700
Fax: +44 (0) 1335 347711
Email: sales@mastermover.com
Web: www.mastermover.com

MasterMover® is a Registered Trade Name. All Rights Reserved. ©2009 MasterMover® Ltd.
We operate a policy of continued improvement in our product range. We therefore reserve the right to amend specifications and descriptions at any time without prior notice.

Designed and manufactured in the UK

